

Sink Diade Gun Metal

Kitchen Sinks

Code: 3028 856



DETAILS

Edge/Installation Type	Undermount
Material	AISI 304 stainless steel
Texture	Brushed in line
Finish	Foster brushed
Finish	PVD
Coloring	Gun Metal
Base	90 cm
Width	80 cm
Dimensions	800 x 440 mm

Bowl dimension 760 x 400 mm

Built-in hole [View technical data sheet](#)

Standard fittings Fixing hooks, drain, overflow and siphon, boxed packing

Mixer holes No standard holes

Drainer No

Number of bowls 1 bowl

Waste fitting 3,5" drain

FEATURES

Basket 3,5" waste fitting The drain is equipped with a large 3.5" drain, with the practical basket cap that prevents the discharge of solid parts.

Deep bowls This bowls reach an important depth, over 20 cm, thanks to the advanced production technology, that can be offer great capiciency and practicity in all the washing operations.

Gun Metal The Gun Metal finish is obtained by treating steel with a physical process called PVD (Phisical Vacuum Deposition) which deposits particles of noble metals on the surface. The result is a unique and refined aesthetic effect, and an improvement of the mechanical properties of the steel which is more resistant to impact and scratches.

High thickness 1mm thick steel. A significant thickness, which guarantees the maximum sturdiness and durability.

MOULDED BOTTOM The moulded bottom guarantees perfect water flow and facilitates cleaning operations thanks to the perimeter step with sloping walls.

Perimetral overflow

The overflow is always a security on the Foster sinks that prevents the overflow of water in case of oversights. The perimeter drain solution improves aesthetics thanks to its square and essential shape.

TECHNICAL DATA

Sottotop/Under-mount
Base 90 | 90 Cabinet

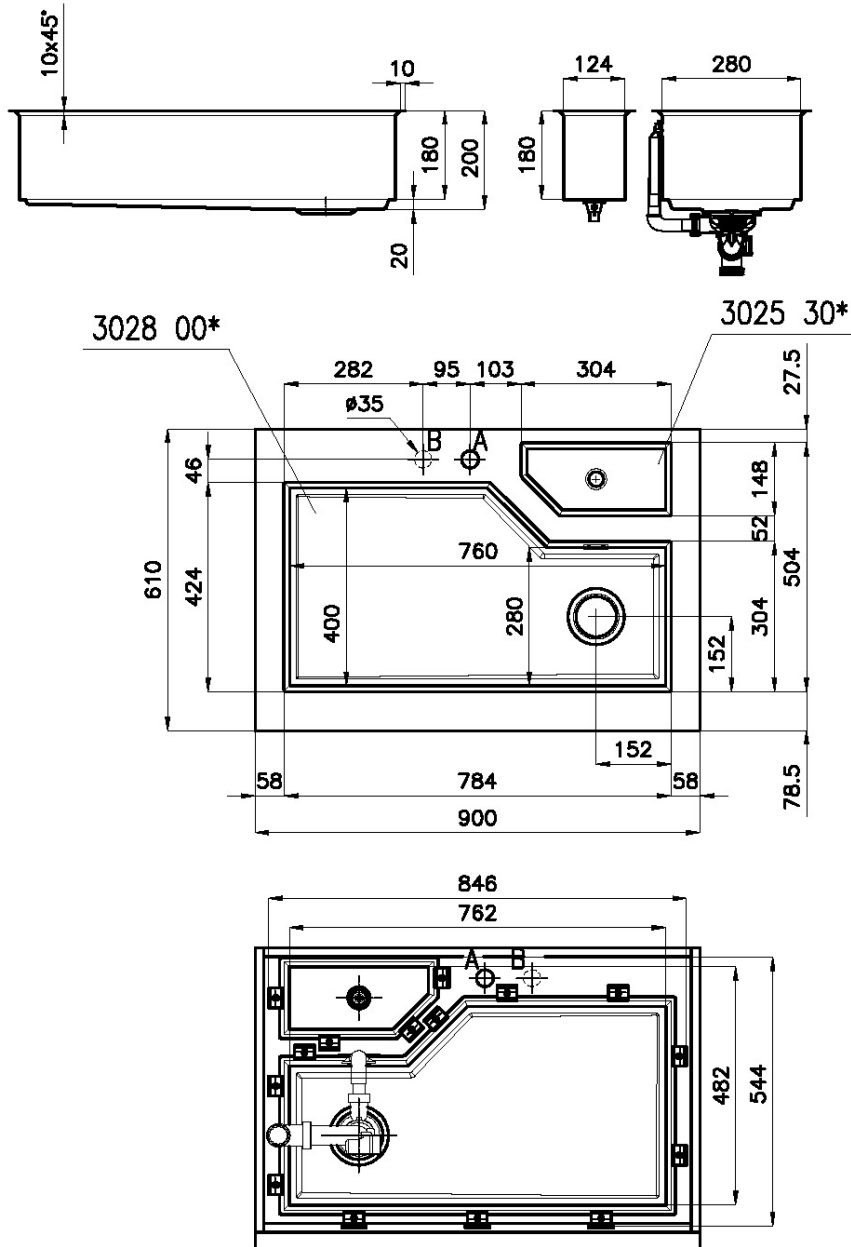

A: Foro Mix/Mixer tap cut-out

B: Foro comando automatico piletta/Automatic waste-fitting command cut-out

Sottotop/Under-mount Base 120 | 120 Cabinet

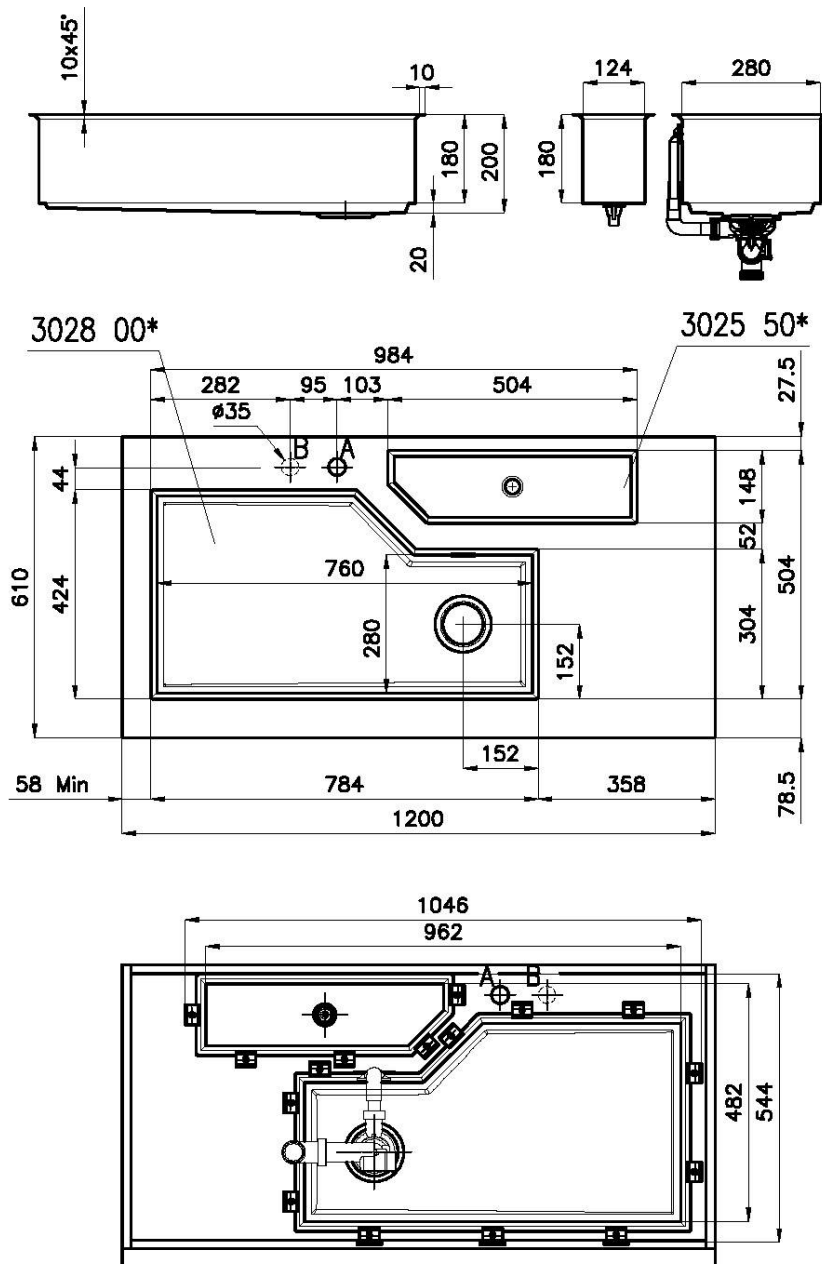

A: Foro Mix/Mixer tap cut-out

B: Foro comando automatico piletta/Automatic waste-fitting command cut-out

Sottotop/Under-mount

Base 90 | 90 Cabinet

Cut out size

Dimensioni per foratura top

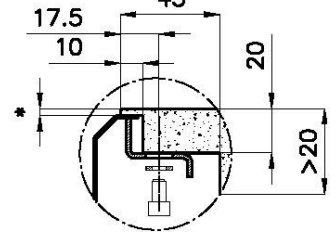
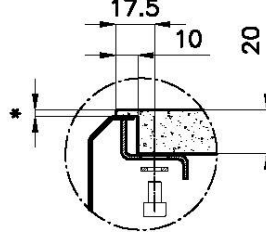
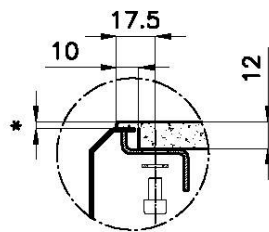
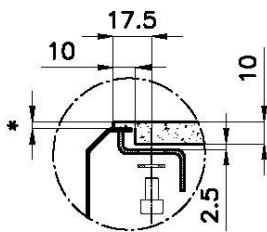
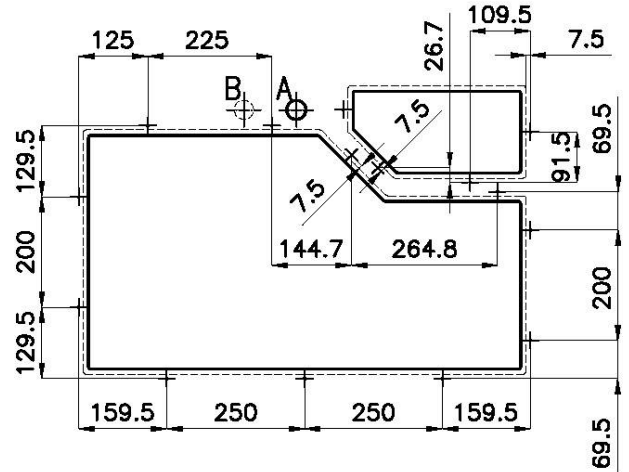
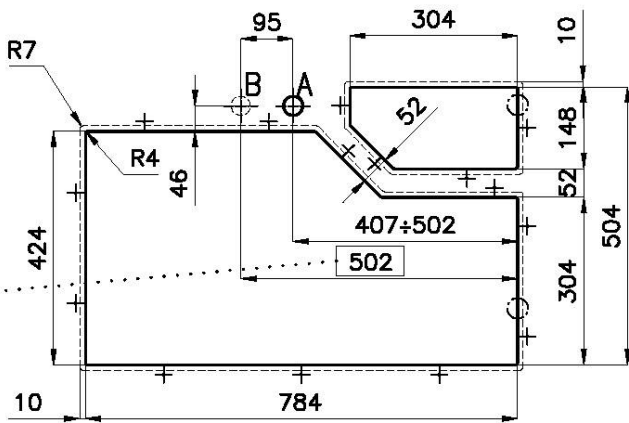

Quota max per piletta automatica / Max quote for automatic drain

*lo spessore minimo deve essere valutato in base alla resistenza del materiale

*Minimum thickness must be evaluated in reference to the material's resistance

sink thickness/spessore acciaio

1

Sottotop/Under-mount Base 120 | 120 Cabinet

Cut out size
Dimensioni per foratura top

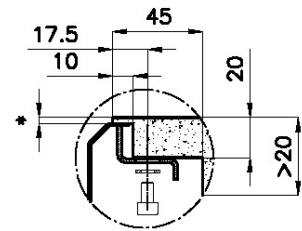
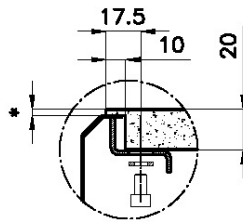
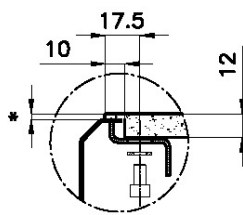
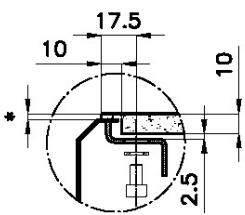
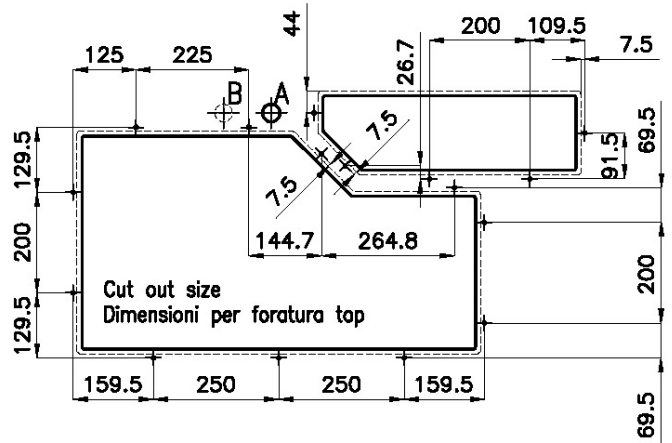
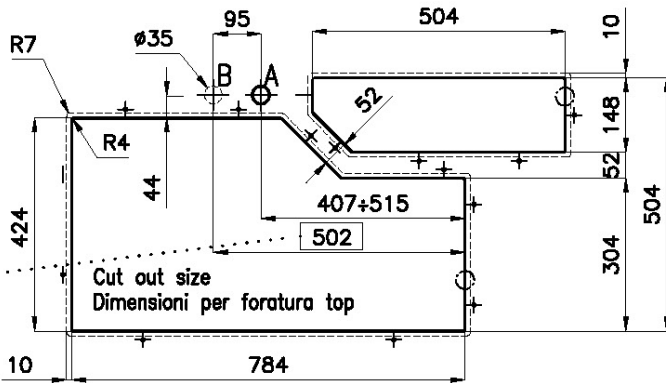

Quota max per piletta automatica / Max quote for automatic drain

*lo spessore minimo deve essere valutato in base alla resistenza del materiale
*Minimum thickness must be evaluated in reference to the material's resistance

sink thickness/spessore acciaio 1

SOTTOTOP

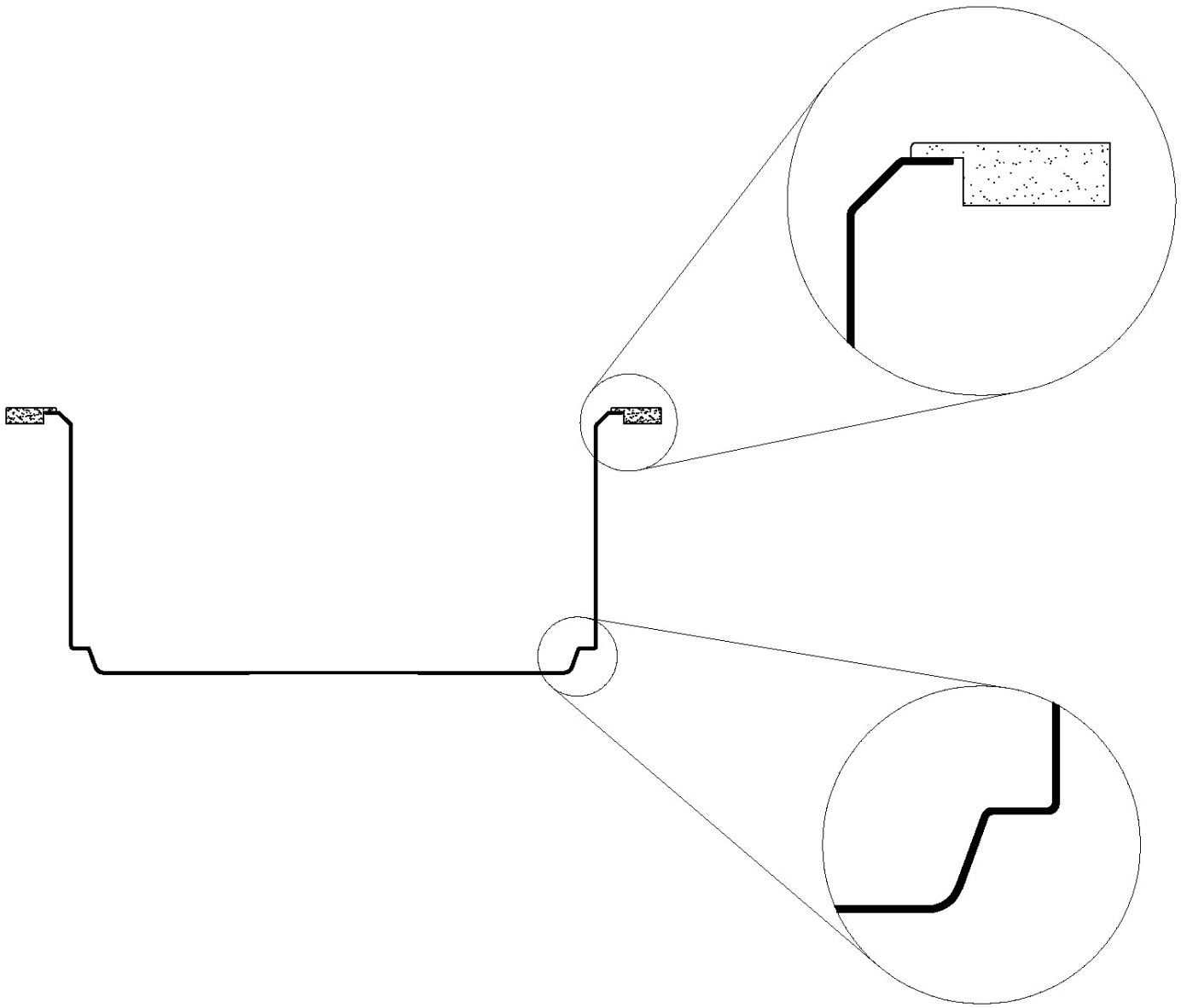

GALLERY



EQUIPMENT



Black multifunction chopping board

8100 608

OPTIONAL ACCESSORIES



Black lid

8151 005



Iroko-wood round chopping board

8642 005



Stainless steel colander

8151 010



Stainless steel perforated tray

8151 001

RECOMMENDED PAIRINGS



VOLTA GUN METAL
8491 106



Dispenser Evo satin Gun Metal
8520 156



Diade equipped troughs Gun Metal
8100 836



Diade equipped troughs Gun Metal
8100 856



Diade equipped troughs Gun Metal
8100 866

OPTIONAL AUTOMATIC WASTE FITTINGS



**Space Push Gun Metal automatic
waste fitting - PO**
8407 120